

## FITTING INSTRUCTION

Clamp mark in acc. with		Cables joining
ISO	PN	
1	L	Left directional lights
2	+	Rear fog lights
3	31	Ground
4	R	Right directional lights
5	58R	Right side parking lights
6	54	Stoplights
7	58L	Left side parking lights

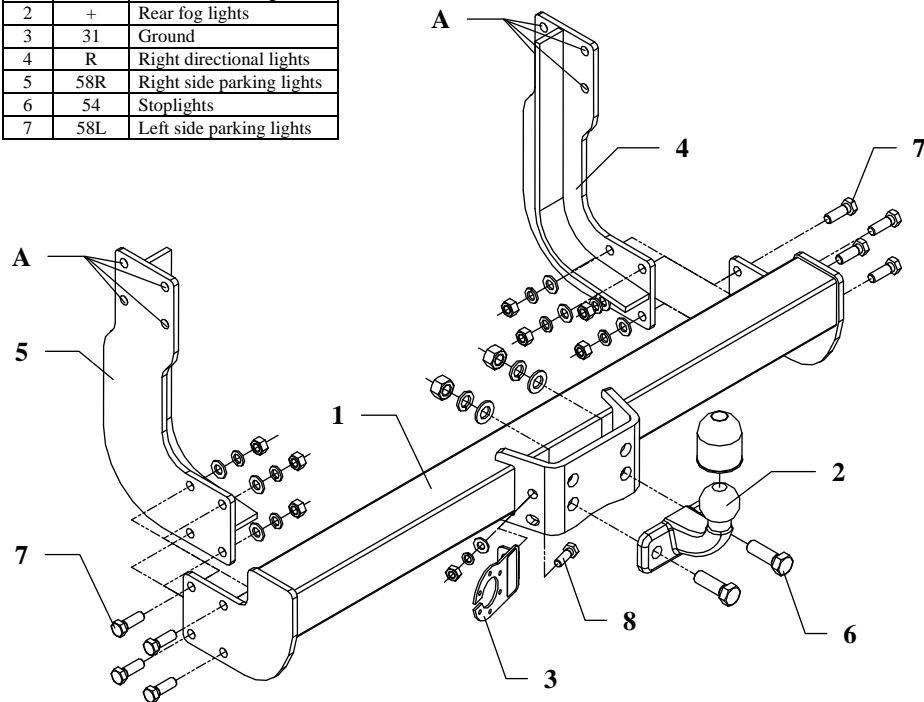

This towing hitch is designed to assembly in following cars:  
**MERCEDES SPRINTER**, produced since 02.1995 till 05.2006 and  
**VOLKSWAGEN LT 28/46**, produced since 01.1996 till 03.2006  
**3,05/3,55/4,025m, loading platform, double wheels**, catalogue no. **D15**  
 and is prepared to tow trailers max total weight **2800 kg** and max vertical  
 load **100 kg**.

### *From manufacturer*

Thank you for buying our product. Their reliability has been confirmed in many tests. Reliability of towing hitch depends also on correct assembly and right operation. For this reasons we kindly ask to read carefully this instruction and apply to hints.

*The towing hitch should be installing in points described by a car producer.*

## The instruction of the assembly

1. Disassemble bolts from chassis members on the left and right side of the car in places where will be mount the towing hitch.
2. Put side brackets of the towing hitch (pos. 4 and 5) on the left and right side of the chassis members and next fix it through holes pos. A using original bolts.
3. Between installed side brackets put main bar of the towing hitch (pos. 1) and fix with brackets using bolts M12x35mm (pos. 7) from equipment.
4. Fix tow-ball (pos. 2) using bolts M16x50mm (pos. 6) from equipment.
5. Fix the socket plate (pos. 3) as shown on the drawing using bolt M10x30mm (pos. 8).
6. Tighten all bolts according to the torque shown in the table.
7. Connect electric wires of 7-poles socket according to the instruction of the car. (Recommend to make at authorized service station).
8. Complete paint layer damaged during installation.

Torque settings for nuts and bolts (8,8):

<b>M6</b> - 11 Nm	<b>M8</b> - 25 Nm	<b>M10</b> - 50 Nm
<b>M12</b> - 87 Nm	<b>M14</b> - 138 Nm	<b>M16</b> - 210 Nm

### NOTE

After install the towing hitch you should get adequate note in registration book (at authorised service station).The car should be equipped with:

- Indicators
- Tow mirrors

Check all bolts and nuts after 1000km of exploitation. The ball of towing hitch must be always kept clear and conserve with a grease.

## Part list:

Pos. 1 Main bar PCS.: 1	Pos. 5 Left bracket PCS.: 1	Pos. 10 Plain washer ø12mm PCS.: 8	Pos. 15 Nut 8 B M16 PCS.: 2
	Pos. 6 Bolt 8,8 B M16x50mm PCS.: 2	Pos. 11 Plain washer ø10mm PCS.: 1	Pos. 16 Nut 8 B M12 PCS.: 8
Pos. 2 Tow ball PCS.: 1	Pos. 7 Bolt 8,8 B M12x35mm PCS.: 8	Pos. 12 Spring washer ø16,3mm PCS.: 2	Pos. 17 Nut 8 B M10 PCS.: 1
Pos. 3 Socket plate PCS.: 1	Pos. 8 Bolt 8,8 B M10x30 PCS.: 1	Pos. 13 Spring washer ø12mm PCS.: 8	Pos. 18 Ball cover PCS.: 1
Pos. 4 Right bracket PCS.: 1	Pos. 9 Plain washer ø17mm PCS.: 2	Pos. 14 Spring washer ø10mm PCS.: 1	



## PPUH AUTO-HAK S.J.

Produkcja Zaczepów Kulowych  
Henryk i Zbigniew Nejman  
76-200 SŁUPSK ul. Słoneczna 16K  
tel/fax (059) 8-414-414; 8-414-413  
E-mail: [office@autohak.com.pl](mailto:office@autohak.com.pl)  
[www.autohak.com.pl](http://www.autohak.com.pl)

### Towing hitch (without electrical set)

Class: **A50-X** Cat. no. **D15**

Designed for:

**MERCEDES SPRINTER**

Type: **3,05/3,55/4,025m,**

**loading platform, double wheels**

**produced since 02.1995 till 05.2006**

and

**VOLKSWAGEN LT 28/46**

Type: **3,05/3,55/4,025m, loading platform, double wheels**

**produced since 01.1996 till 03.2006**

**Approval number according to Directive 94/20/EC: e20\*94/20\*0475\*00**

Technical data:

**D-value: 15,26 kN**

maximum trailer weight: **2800 kg**

maximum vertical cup load: **100 kg**

### Foreword

This towing hitch is designed according to rules of safety traffic regulations. The towing hitch is a safety component and can be install only by qualified personnel. Any alteration or conversion of the towing hitch is prohibited and would lead to cancellation of design certification. Remove insulating compound and underseal from vehicle (if present) in the area of the matting surfaces of the towing hitch.

The vehicle manufacturer's specifications regarding trailer load and max. vertical cup load are decisive for driving whereat values for the towing hitch cannot be exceeded.

*D-value formula:*

$$\frac{\text{Max trailer weight [kg]} \times \text{Max vehicle weight [kg]}}{\text{Max trailer weight [kg]} + \text{Max vehicle weight [kg]}} \times \frac{9,81}{1000} = D \text{ [kN]}$$